

**Due: October 30, 2003**

1. (20 points) Draw schematics for the following functions using AND, OR and NOT gates. (Do not simplify the formulas.)
  - (a)  $X(Y + Z)$
  - (b)  $\overline{X + YZ}$
  - (c)  $\overline{X(Y + Z)}$
  - (d)  $W(X + YZ)$
2. (10 points) Question A.3, page 493, Murdocca & Heuring
3. (10 points) Prove the Consensus Theorem  $AB + \overline{A}C + BC = AB + \overline{A}C$  using the postulates and theorems of Boolean algebra (except the Consensus Theorem itself) in Table A-1 (p. 451). *Hint: use absorption creatively.*
4. (40 points) For each CMOS circuit below,
  - (a) Provide a truth table for the circuit's function.
  - (b) For diagram (a), write down the Sum-of-Products (SOP) Boolean formula for the truth table. For diagram (b), write down the Product-of-Sums (POS) Boolean formula.
  - (c) Simplify the SOP or POS formula using the postulates and theorems of Boolean Algebra (p. 451). *Show all work.*
  - (d) Draw the logic diagram of the simplified formula using AND, OR, NAND, NOR and NOT gates.

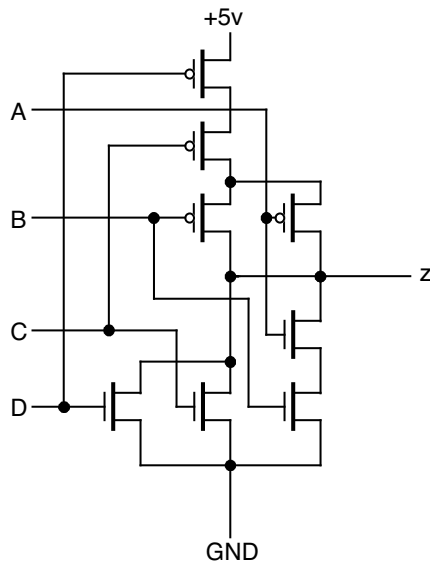

(a)

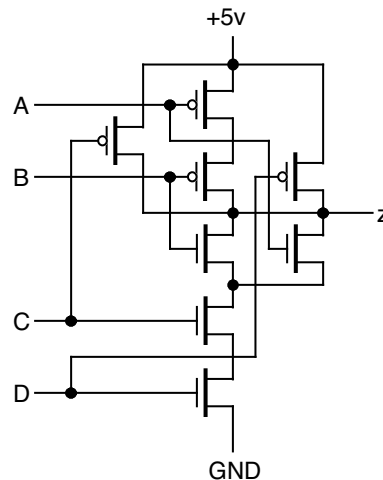

(b)