

DigSim Assignment 1: Getting Started

Due: Thursday October 31, 2002

Objective

The objective of this assignment is to make sure that everyone has access to DigSim and, most importantly, can save DigSim circuits for submission.

Assignment

Using DigSim, wire up the following circuit diagram, play with the switches, create a text box with your name, and save the circuit diagram.

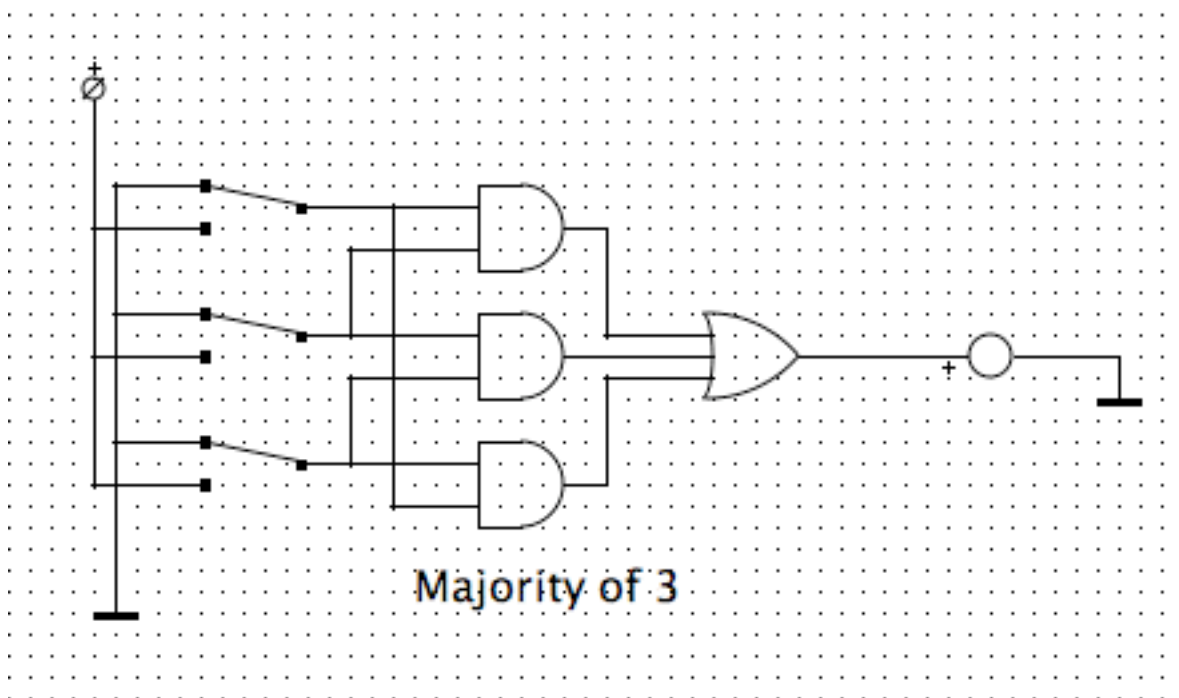

Turning in your program

The file which has your circuit diagram should be a plain text file that starts with something like:

```
# Digsim file
version 1 0
describe component ThreeOrPort
pos 31 15
```

Use a text editor to look at the file and make sure that the file is not empty and has some data similar to the above. Next, use DigSim to load the file and make sure that this still works. If all is well, submit the circuit file using the Unix submit command as in previous assignments. The submission name for this assignment is :digsim1. The UNIX command to do this should look something like:

```
submit cs313-0101 digsim1 majority3.sim
```